

PRODUCT SPECIFICATION

PRODUCT SPECIFICATION



High Power DMX Decoder&driver
Model: PX24500(RJ45 INTERFACE)

Meets DMX512/1990
Can drive 5A(Each CH.)
Can drive many kinds of LED lamps

PRODUCT SPECIFICATION

Updated at 2009-4-22

SUMMARIZE

Thank you for using PX series DMX512 decoder. With advanced micro-computer control technology, PX series convert the widely used DMX512/1990 signal to analog signal. Can choose 1~3 output channel, 256-level brightness control. For connecting of light console and analog device, or lighting & building lamps controlling.

FEATHERS

- ◆ Meets DMX512/1990
- ◆ 256-level brightness, full-color control
- ◆ 3 output CH., can drive 5A (Each CH.)
- ◆ With control system, can express perfect effect
- ◆ Can drive 1~3 channel of each lamp
- ◆ Can set the DMX address freely
- ◆ High interference resistant, over-heat and over-current protect, self-recovery function available
- ◆ Can be custom-made

TECH. CHARACTERISTICS

Decode CH.: 1~3
Input Signal: DMX-512/1990 digital signal
Output Signal: 0~24V PWM signal, can drive 5A (Each CH.)
Power Supply: DC, +12~25V
Power Dis.: <1W
Power Output: <360W(24V); <180W(12V)
Operating Temp.: 0~70°C
Size: 175(mm)*45(mm)*35(mm), can be custom-made
Weight: ≤300g

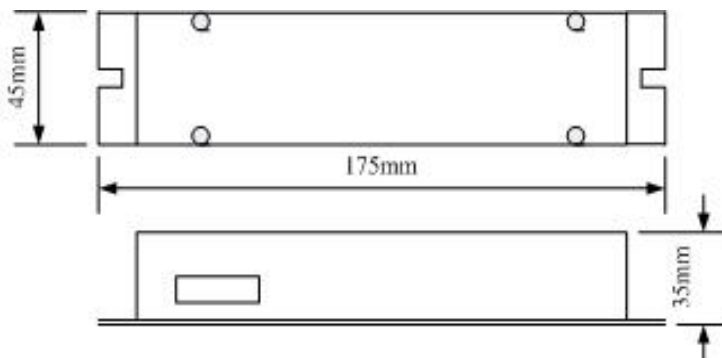
DIMENSION

Internal Block Diagram

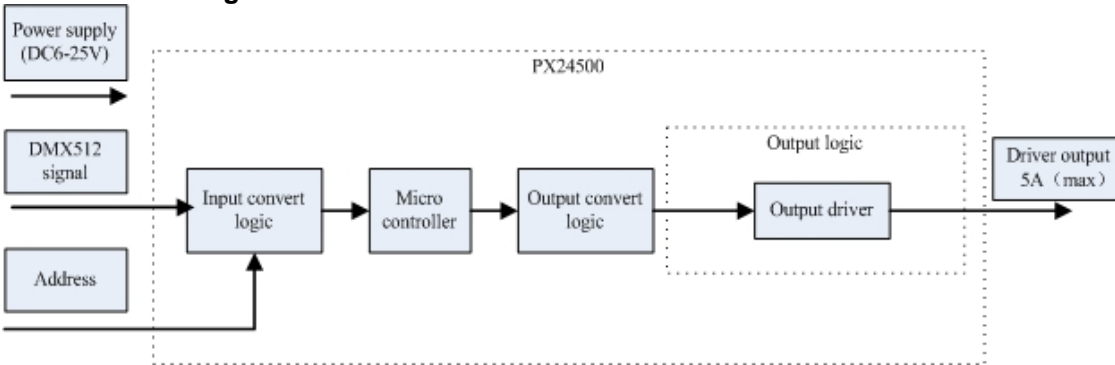

Appearance

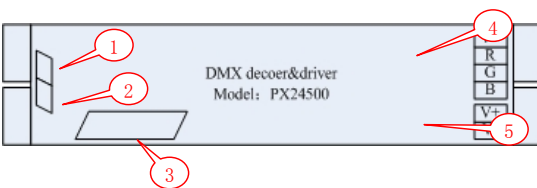

- (1) DMX signal input interface(RJ45)
- (2) DMX signal output interface(RJ45)
- (3) Address setting interface
- (4) Driver output interface
- (5) Power input interface

Interface Introduction

◆ DMX signal interface

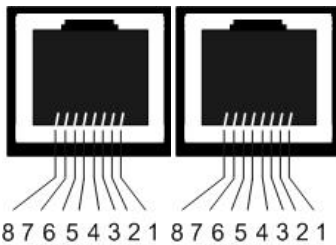

- 1: DATA+
- 2: DATA-
- 3-6: NC
- 7-8: GND

◆ Address setting interface

Please find the detailed instruction for Address setting at Page 5.

◆ Power input interface

DC 12-25V input, supply power for decoder and the lamps it takes.

◆ Driver output interface

Common anode, V+ and R,G,B interface, can drive kinds of RGB module or single-color module, Can regulate output current according to the actual load.

remark:

Connect the anode and RGB wire of common anode RGB module to the output interface of decoder directly; Connect the anode wire of single-color module to V+ on decoder, and connect the cathode wire to one of RGB pin according to the LED's color; Connect several colors single-color module to one decoder, please connect their anode wires to V+ pin on decoder.

How To Use

PX24500 is controlled by DMX-512 digital signal。The frontage is DMX512 transmitter, take EC-DMX512 for example,to control 0~24V analog devices.We suppose to drive LED to introduce it.The connecting is below:

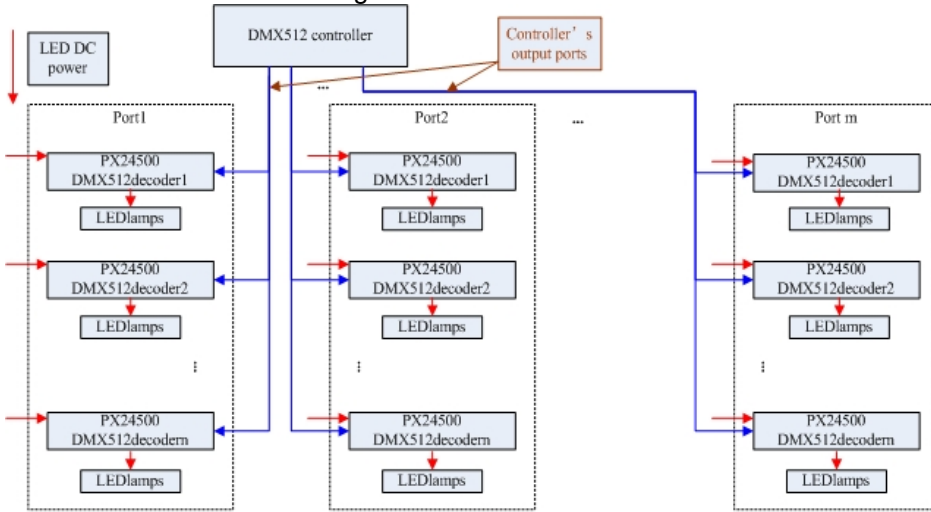

Notes:
 1.m is the amount of controller output port
 2.n is the max. amount of terminals for each port
 The upwards is according to controller

TYPICAL APPLICATIONS

◆ Circuit Diagram 1

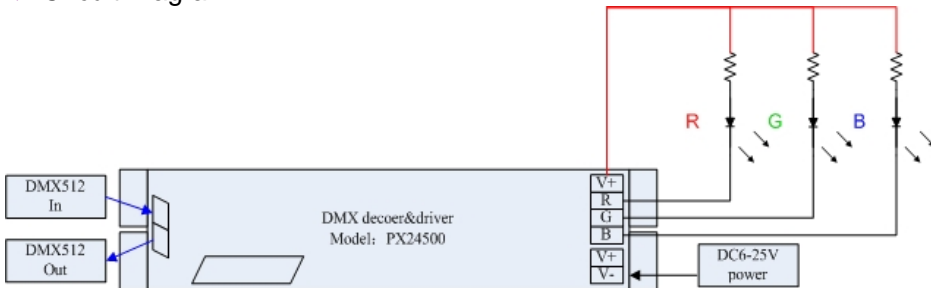

Connecting of DMX-512 Signal

- ◆ The wire for DMX signal is STP, the DMX signal has positive and negative signal. Pay attention to the polarity while soldering.Connect the positive signal,negative signal and GND to the corresponding signal of PX24500.
- ◆ Connect a signal terminal at the end of the whole connetion.

Calculate the power

This product has a wide input/output voltage(DC 6-25V),it's rating current is 5A,so the rating power is different in different input,for example:

Rating power in 12V: $12V \times 5A \times 3 = 180 \text{ W}$

Rating power in 24V: $24V \times 5A \times 3 = 360 \text{ W}$

DMX-512 Address Setting

The DIP switch on PX24500 can set the binary value of the DMX512 address to receive data.

The correlative bits is the 1-9 bits of the DIP switch,the 1st bit is LSB,the 9th bit MSB 512 addresses totally.The start address is the no. of the first channel of the decoder , the second channel will receive the data of start address+1,and the third channel will receive the data of start address+2.There are two way to find out the relation between the DIP switch and DMX address.

calculational method:

calculational formula: [the sum of 1~9 bit of the DIP switch] = DMX start address

Set the n(th) bit of the DIP switch up (set to“1”) to get the value of such bit;

Set the n(th) bit of the DIP switch down “0”) , so the value of this bit is 0.

Note: the 10th bit is not use.

Value of each DIP:

DIP	1	2	3	4	6	7	8	9
Value	1	2	4	8	32	64	128	256

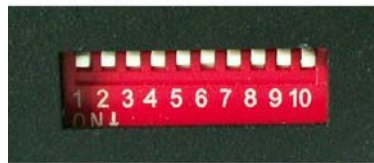

Example 1: Set to 38

Set the 6th,3rd,1st bit of the DIP switch to“1”, others set to“0”, then the sum of the 1~9 is $32+4+2$, is the start address 38.

That is: $[32 + 4 + 2] = 38$



Example 2: Set to 226

Set the 8th,7th,6th,1st bit to“1”, others set to“0”, then the sum of the 1~9 is $128+64+32+2$, is the start address 226.

That is: $[128 + 64 + 32 + 2] = 226$

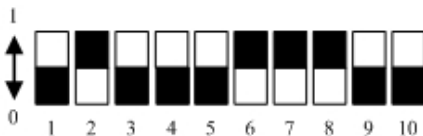

The contents about the product install and usage

Principle:

- (1)The input voltage should be limited in rated range.
- (2)Do not use it by over load.
- (3)Installed in suited environment.
 - A.The driver can not be setting in high temperature or wet conditions
 - B.We recommend three ways to take away the heat as follows
 - ①Bared in moving air
 - ②Put in a big enough space for taking away the heat
 - ③Fixed on big metalline board, and make sure they are contacted well

The contents about install and usage

- (1)When work with controller, put the controller close to avoid the signal become weak.
- (2)The reliable length of the control line is 200m.
- (3)Recommend to use the STP with the characteristic impedance of 120 ohm
- (4)The signal line should be one bus, and the signal line pass in and out the decoder ports directly
- (5)Make sure the signal line connector and the decoder's signal port are well connect
- (6)Add a signal terminator at the end of the signal line
- (7)The decoder should be closed to the lamps. If the lamps is over 5 meters, the ones follow should be joined at the decoder's out port again
- (8)Adopt thicker power cable with good conductivity
- (9)If one decoder take several lamps in series , make sure the lamps's connectors are firmly connected
- (10)Signal line should be far away with the 110/220V AC cable
- (11)For these conditions: bad environment, long line, more than 20 decoders on line, please reduce the load of decoders, commonly less than 100w on each one.

Install Cases:

(in attached drawing,the unconscionable of install cases were labeled by "X")

(1)The bad install manners of take away the heat and the right ways:

the wrong of install manners

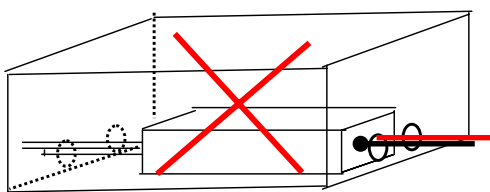

the decoder can't be set in airtight conditions

the right of install manners

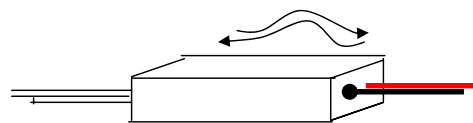

Bared in moving air

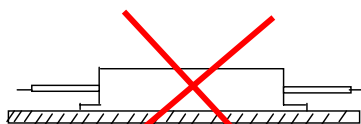

woodwork(plastic)



metal

ventilation well

(2)The install manners with weak signal and the right ways :

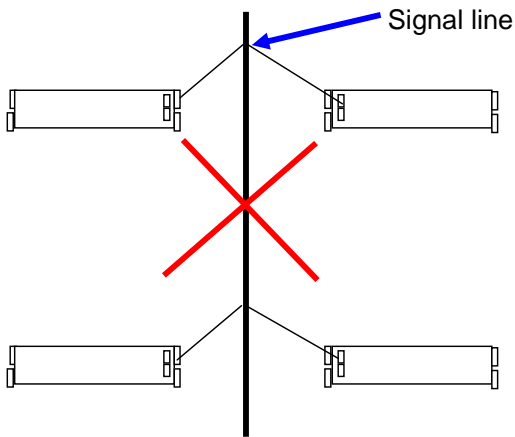

the signal line was linked side by side

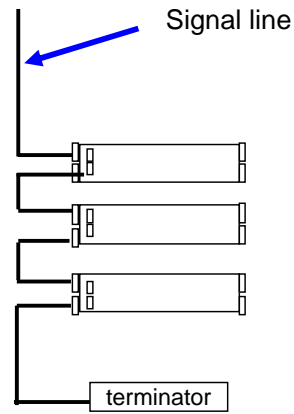

The signal line should be one bus and add a signal terminator at the end of it

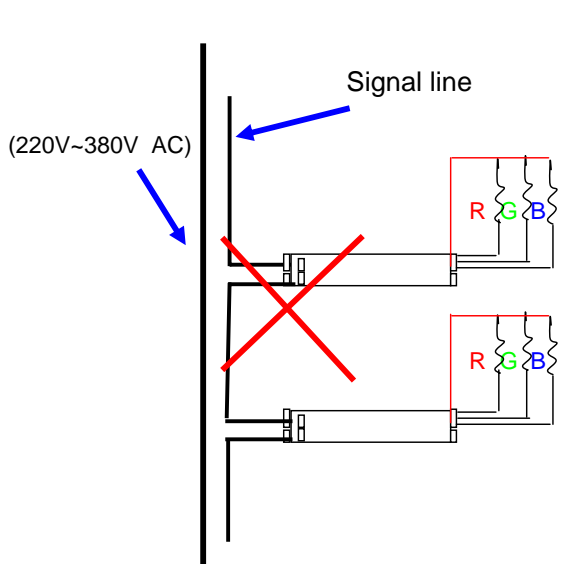

Signal line was closed to the 220/380V AC

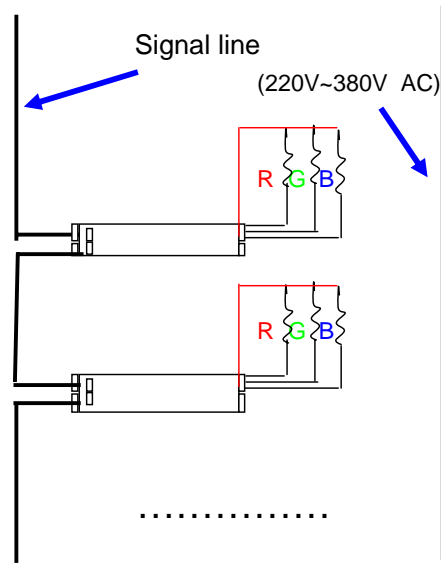

Signal line should be far away with the 220/380V AC

Troubleshooting Guide

Problem	Reason	Solution
1.All the lamps were off	The power wire not connected well or no output	Reconnect the power wire or change a power supply
	Lamp's power wire not connected well	Reconnect the power wire
	Signal terminal not connected well or the signal wires were reverse	Reconnect the signal cable
	Line is too long, for over 300m	Add terminator or amplifier
2.One or several lamps not change	Signal terminal not connected well or the signal wires were reverse	Reconnect the signal cable
	Line is too long, for over 300m	Add terminator or amplifier
3.Some color was off	Wire of this color not connected well	Reconnect the power wire
4.Wrong color was shining in change	Power wire were reverse	Reconnect the power wire
	Decoder address was wrong	Change the address (refer to the address table)
5.Irregular flicker	Signal terminal not connected well	Reconnect the signal terminal
	Line is too long, for over 300m	Add terminator or amplifier

If still can not figure out, please contact our technician.